

781 Series Commercial Transport System (CTS) Installation and Operation Manual January 16, 2009

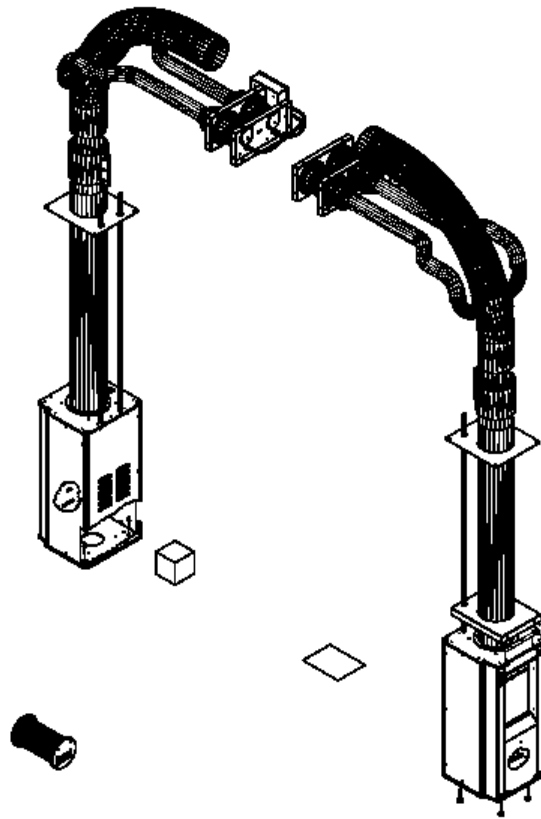



7500 Mars Drive
Waco, TX 76712
(254) 776-0100 P
(254) 776-0700 F
www.AmericanVault.us

This page is blank

TABLE OF CONTENTS

DISCLAIMER

WARNINGS

1 INTRODUCTION

- 1.1 Product Overview
- 1.2 General Specification
- 1.3 Part Names-System (Figure 1-1)
- 1.4 Part Names-Teller Terminal (T/T) (Figure 1-2)
- 1.5 Part Names-Customer Terminal (C/T) (Figure 1-3)
- 1.6 Part Names-Air Handler (A/H) (Figure 1-4)

2 INSTALLATION

- 2.1 Safety and Pre-Installation Procedures
- 2.2 Apparel
- 2.3 Site Requirements
- 2.4 Unpacking Instructions
- 2.5 Opening Details
Figure 2-1 (Drawing #20142)
- 2.6 Installation Procedure
Figure 2-2 (Drawing #781-1001-01)

3 OPERATION

- 3.1 Switches and Indicators-Customer Terminal (C/T)
- 3.2 Devices-Customer Terminal (C/T)
- 3.3 Switches and Indicators-Teller Terminal (T/T)
- 3.4 Devices-Teller Terminal (T/T)
- 3.5 Devices-Air Handler (A/H)
- 3.6 Functions
- 3.7 Sequence of Operation

TABLE OF CONTENTS (continued)

4 MAINTENANCE

- 4.1 Cleaning
- 4.2 Preventative Maintenance

5 SERVICE

- 5.1 Service Functions-Teller Terminal
- 5.2 Service LED's-Teller Terminal
- 5.3 Service functions-Customer Terminal
- 5.4 Service LED'S-Customer Terminal
- 5.5 Field Wiring
- 5.6 Audio Wiring
- 5.7 Audio Mute Selector
- 5.8 Flash Indicators
- 5.9 System Start-Up
- 5.10 Function Test-Customer Terminal
- 5.11 Function Test-Teller Terminal
- 5.12 Troubleshooting Guide

Figure 5-1 Block Diagram-C/T (Drawing #781-1801)

Figure 5-2 Block Diagram-T/T (Drawing #781-2801)

Figure 5-3 Block Diagram-A/H (Drawing #781-4001)

Figure 5-4 Part Names-781 CTS C/T PCB Assembly

Figure 5-5 Part Names-781 CTS T/T PCB Assembly

DISCLAIMER

The material in this manual is for information purposes only. The contents and the product described are subject to change without notice. The manufacturer makes no presentations or warranties with respect to this manual. This product was designed for certain applications only. It may not be modified and/or used for any applications other than that which it was designed. The design specifications of the product described herein is subject to change without notice. The manufacturer reserves the right to make such changes without incurring any obligation to make them in units previously sold. Differences between the unit you received and the views contained herein are the result of design improvement and/or the addition of options as specified.

WARNINGS

CAUTION: If not properly installed, operated and maintained, the use of this equipment presents the possibility of personal injury or property damage. Before use, all persons who will install, operate or maintain this product should read this manual thoroughly. For safe, dependable performance, follow all instructions and recommendations contained herein.

CAUTION: To prevent fire or shock, do not expose this product to rain or any type of moisture.

CAUTION: Keep hands clear of moving parts.

CAUTION: Always unplug the unit from power source prior to cleaning or servicing.

1 INTRODUCTION

1.1 Product overview

This pneumatic tube system is a UL Listed, durable, field proven unit. It has been designed to provide easy access by both customer and teller, and reliable operation under harsh conditions. This pneumatic tube system is for overhead tube applications using the proven pull-pull method. Air Handlers are located in the canopy in close proximity to the terminals and insulated for quiet operation. The teller units are located under the counter.

1.2 General Specifications

1.2.1 Power Requirements:

The branch circuits supplying the Teller & Customer Terminals and Air Handlers must be dedicated circuits using individual hot, neutral and ground conductors. Neither the conduit nor the neutral should be shared with other circuits.

Teller & Customer Terminal: (1) 120 VAC 50/60 Hz, 1PH, 20 Amp Dedicated Circuit

Air Handler (2): (1) 120 VAC 50/60 Hz, 1PH, 30 Amp Dedicated Circuit

1.2.2 Power Consumption:

Teller Terminal: 1 Amp

Customer Terminal: 1 Amp

Air Handlers (2): 18.2 Amps ea.

1.2.3 Maximum package weight: 25 lbs. (1 Quarter Box)

1.2.4 Carrier Volume: 302 cubic inches

1.2.5 Carrier Velocity: 30 feet per second

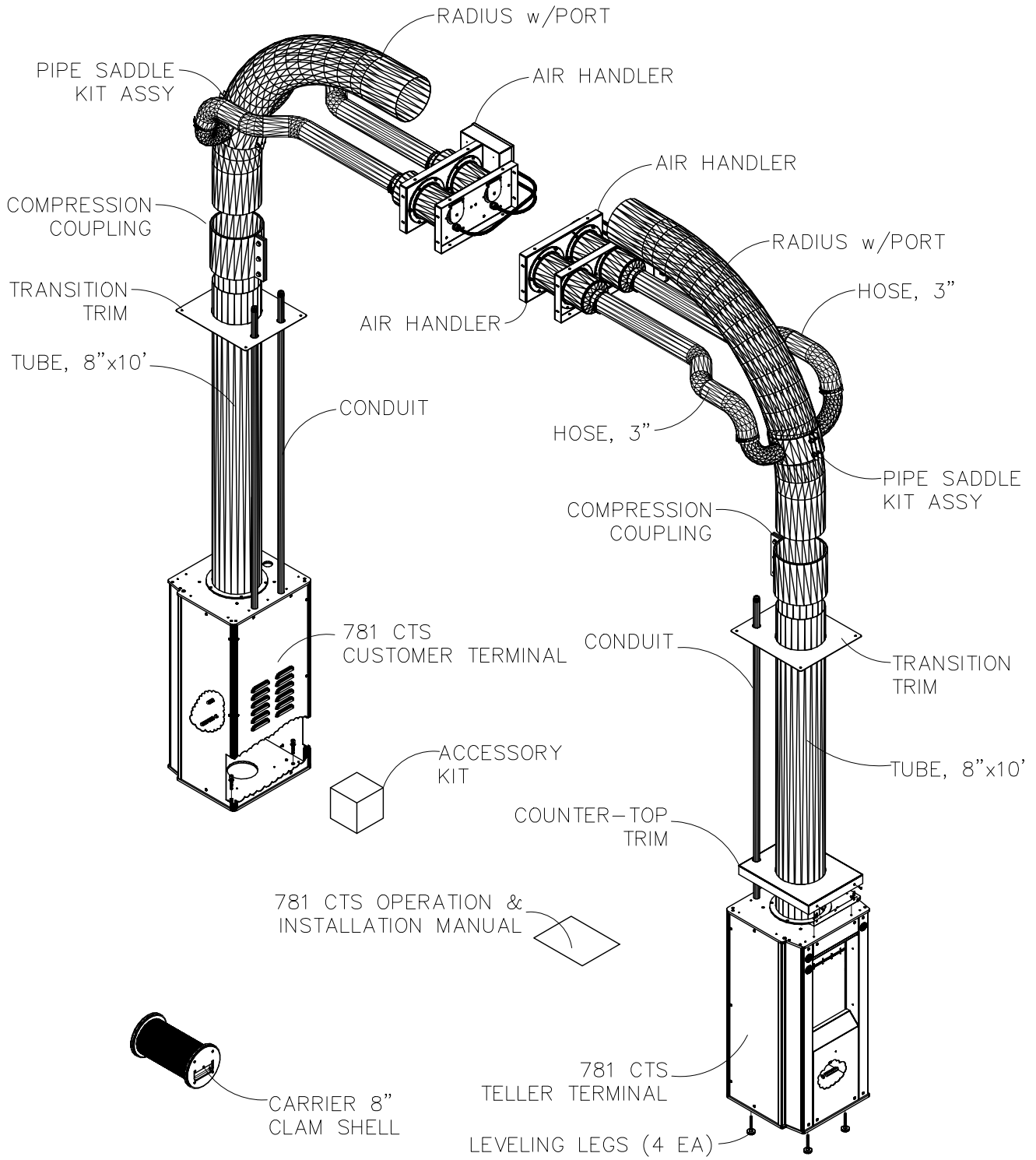

DO NOT SCALE



PRODUCT APPLICATION DRAWING
PART NAMES
781 CTS SYSTEM

SIZE	DWG NO	DATE	SHEET
AA	FIGURE 1-1	01.19.2009	1 OF 1

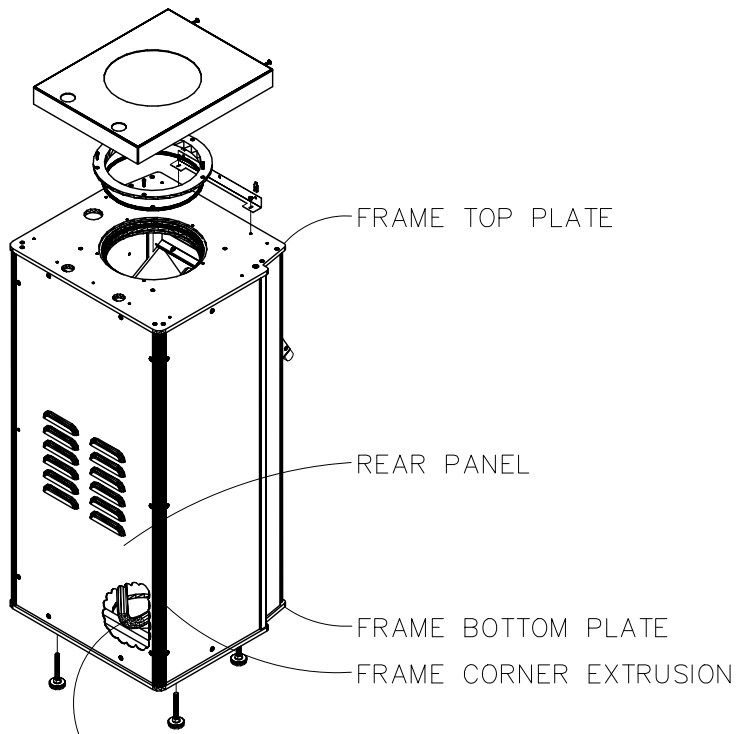

FRAME TOP PLATE

REAR PANEL

FRAME BOTTOM PLATE

FRAME CORNER EXTRUSION

ACCESS HOLE FOR UNDERGROUND WIRING APPLICATIONS

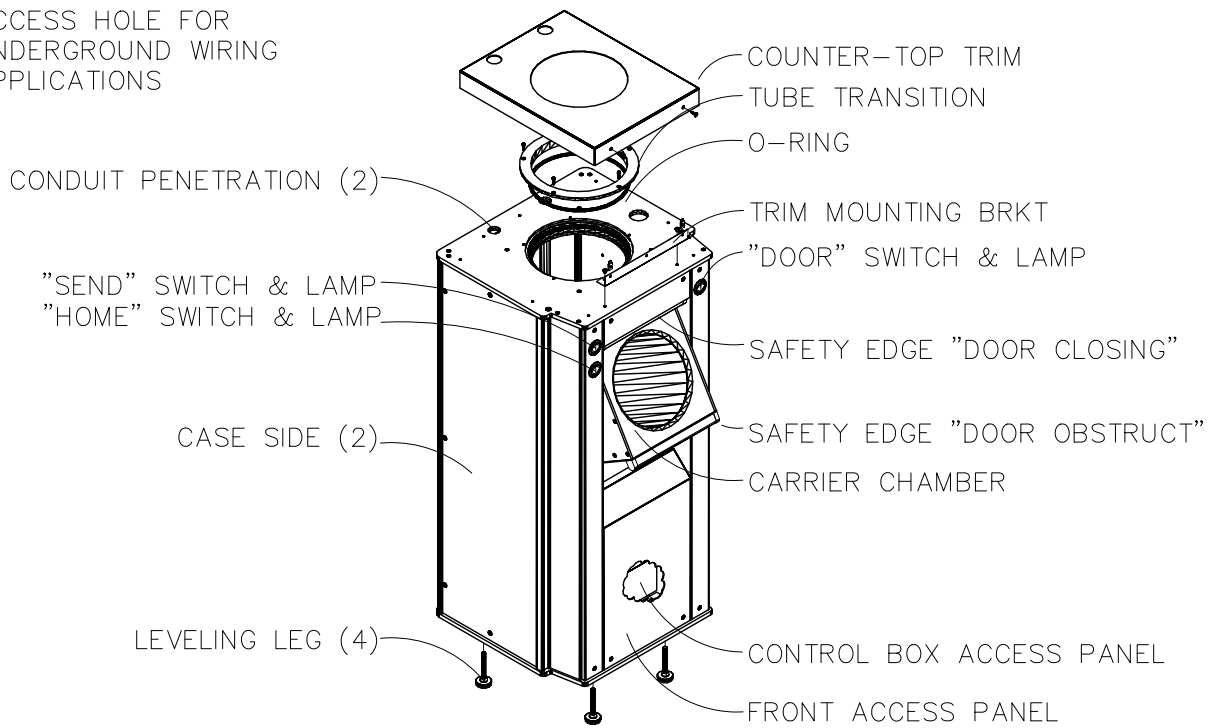

COUNTER-TOP TRIM

TUBE TRANSITION

O-RING

TRIM MOUNTING BRKT

"DOOR" SWITCH & LAMP

SAFETY EDGE "DOOR CLOSING"

SAFETY EDGE "DOOR OBSTRUCT"

CARRIER CHAMBER

CONTROL BOX ACCESS PANEL

FRONT ACCESS PANEL

CONDUIT PENETRATION (2)

"SEND" SWITCH & LAMP

"HOME" SWITCH & LAMP

CASE SIDE (2)

LEVELING LEG (4)

DO NOT SCALE



PRODUCT APPLICATION DRAWING
 PART NAMES
 781 CTS TELLER TERMINAL

SIZE	DWG NO	DATE	SHEET
AA	FIGURE 1-2	01.17.2009	1 OF 1

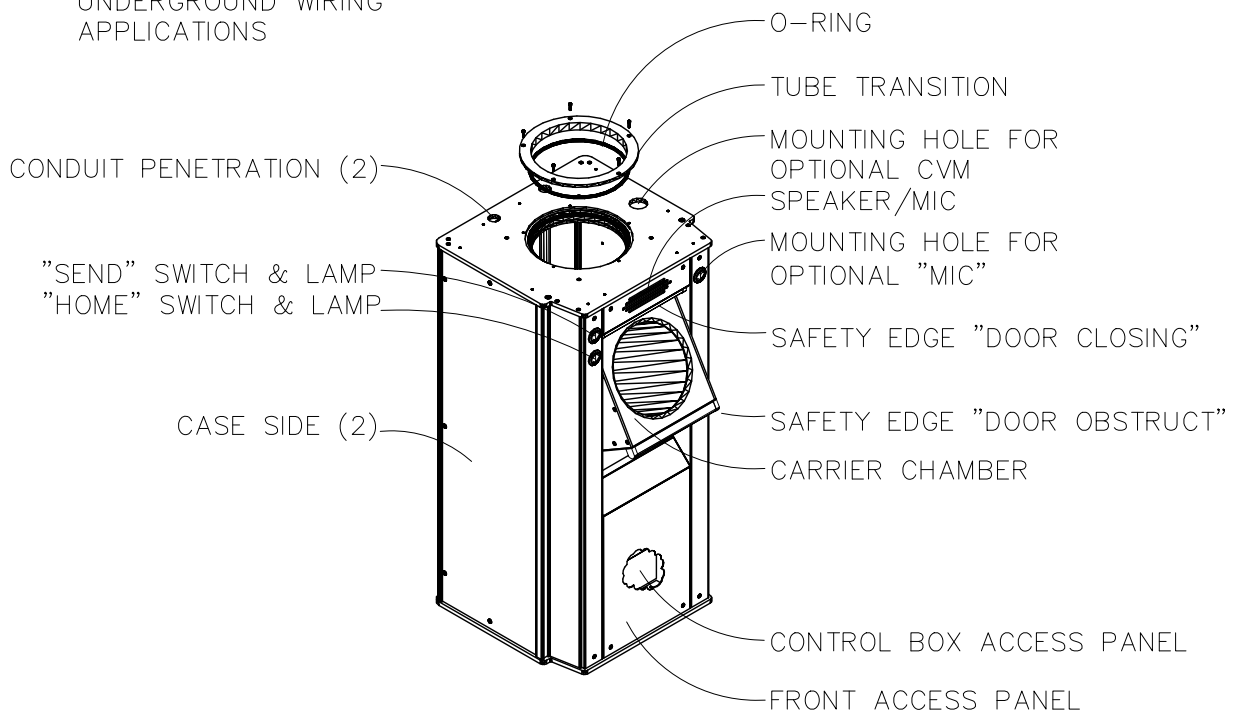
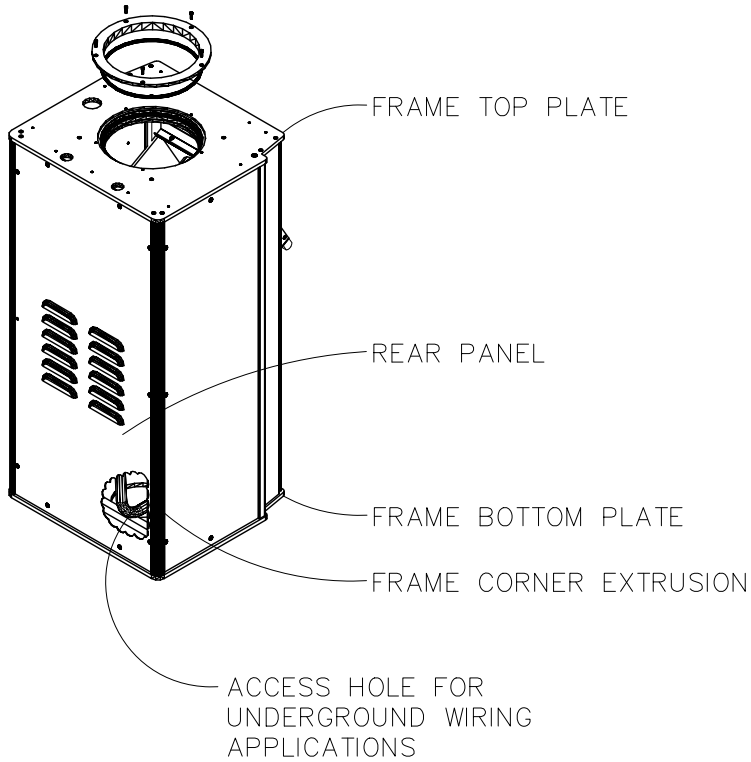

DO NOT SCALE

www.American Vault®.us

PRODUCT APPLICATION DRAWING
PART NAMES

781 CTS CUSTOMER TERMINAL

SIZE	DWG NO	DATE	SHEET
AA	FIGURE 1-3	01.17.2009	1 OF 1

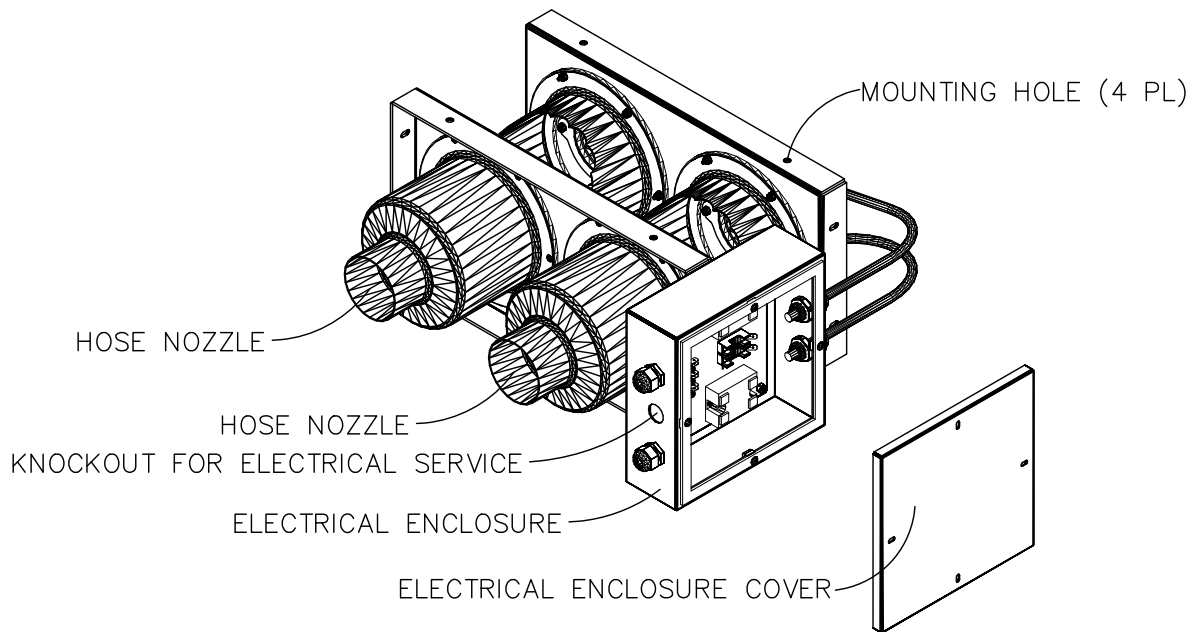
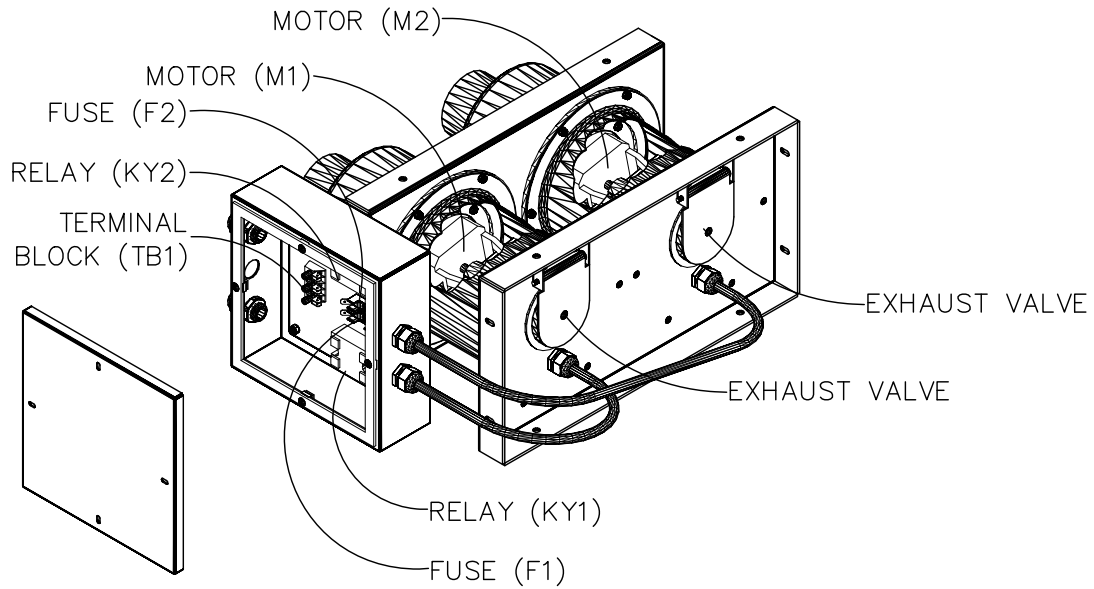

DO NOT SCALE

**www.American
 Vault®
 us**

PRODUCT APPLICATION DRAWING
 PART NAMES
 781 CTS AIR HANDLER

SIZE	DWG NO	DATE	SHEET
AA	FIGURE 1-4	01.17.2009	1 OF 1

2 INSTALLATION

2.1 Safety and Pre-Installation Procedures

- 2.1.1 Only professionals experienced and qualified in the installation should install this product. Misuse, lack of supervision and inspection can contribute to serious accidents or death.
- 2.1.2 Keep the work area clear of all trash and clutter.
- 2.1.3 Because of the extreme and concentrated weight of components; installations can be dangerous. Special methods for installation have been devised. Be sure the appropriate procedures are followed.
- 2.1.4 Know location of the nearest medical facility and "911" availability.
- 2.1.5 Verify the condition of safety equipment and tools.
- 2.1.6 When arriving at job-site introduce yourself to the General Contractor and/or job superintendent, explain:
 - The equipment you will be installing.
 - What your schedule will be.
 - What will be required of the contractor and/or electrician?
- 2.1.7 Check best route into building. Inform G.C. of weights involved. Inform G.C. of existing floor cracks or damage. If a basement or floor exists below the route of travel and/or under the installation area, the G.C. and all trades must be notified.
- 2.1.8 Caution other persons in the building to avoid the installation area. It is recommended to "cordon-off" the area.
- 2.1.9 It is the responsibility of the installer to anticipate and correct all hazardous conditions, including careless or thoughtless act of assistants or technicians who misguidedly try to "help".

2.2 Apparel

- 2.2.1 Personal safety equipment required (but not limited to):
 - Hard Hat, Safety Glasses, Safety Shoes, Gloves, First aid kit
- 2.2.2 Wear a hard hat whenever working at an installation or construction site.
- 2.2.3 Wear high top safety shoes with non-slip soles. Tools, bars, cribbing, rollers, etc. are frequently dropped and can cause injury.
- 2.2.4 Safety glasses are a must.
- 2.2.5 Leather faced gloves should be worn when handling cribbing, cables, chains or unfinished metals.

2.3 Site Requirements

2.3.1 Job Site Conditions

Installer is responsible for ensuring that job site is free and clear of all debris that would prohibit a proper and safe installation (example, construction materials, screws, nails, etc.). Inform G.C. if conditions at job site do not provide a safe working environment.

2 INSTALLATION (continued)

2.4 Unpacking and Inspection

Open shipping carton and remove the contents.

The carton should contain the following items:

- 1 ea. 781 CTS Operation & Installation Manual
- 1 ea. 781-1700 Installation Hardware Kit Assy (containing the following):
 - 5 ea. 8097-0001 Wedge Anchor 3/8x2-3/4
 - 2 ea. 7428-0008 T/Block 8 Pos Plug
 - 2 ea. 7428-0002 T/Block 2 Pos Plug
 - 2 ea. 8340-0012 Nut, U Type Clip, 8-32
 - 2 ea. 8020-1310 TPHMS 8-32x5/16
 - 2 ea. 8020-1316 TPHMS 8-32x1/2
 - 4 ea. 8400-0003 Leveler 3/8-16x2-1/2
 - 8 ea. 8428-0004 H/Clamp 2-3/4 to 3-3/4
- 1 ea. 781-1800 781 CTS C/T Final Assy.
- 1 ea. 781-2800 781 CTS T/T Final Assy.
- 2 ea. 781-4000 781 CTS Air Handler Assy.
- 2 ea. 781-4100 Pipe Saddle Kit Assy.
- 1 ea. 781-5200 Carrier Assy. 8" Clam Shell
- 1 ea. 781-9153 Trim, Counter-Top
- 2 ea. 781-9182 Trim, Ceiling Transition
- 1 ea. 781-9185 Case Side Panel Mounting Bracket
- 4 ea. 700-9911 Conduit, 3/4x10'
- 1 ea. 2275-0004 Hose, Flexible 3"x25' long
- 2 ea. 9033-0001 Steel Tube, 8"x10' long
- 2 ea. 9033-0002 Steel Bend w/Air Port, 8"x32"R
- 2 ea. 9033-0008 Compression Coupling, 8"x8"

2.5 Opening Details (Refer to Figure 2-1 Drawing #20142)

The pneumatic tube system can be installed in most existing drive thru locations. An adequate support structure is required to support the pneumatic tube above the drive thru. It is recommended that the structure be covered to protect the customer terminal from the weather.

Survey above the interior ceiling and canopy area to make sure there are no obstructions, such as HVAC ductwork, electrical, structural, lighting, etc., that will interfere with the tube run. The tube run should be direct, and as straight as possible from the T/T to the C/T without obstructions.

Once the tube path has been determined the GC will need to make a penetration from the exterior wall into the building interior. Make sure the opening is of sufficient size so that the radius will clear the wall. Opening size of 24" square is normally sufficient. This can vary depending on tube path, obstructions, wall thickness and other job specific situations. To prevent the compression coupling and pipe saddle assembly from being exposed below the ceiling line, the top of this opening should be approximately 52" above the ceiling line. If the canopy soffit line is higher than the interior ceiling line and you do not want the radius or compression coupling exposed below the soffit, you will need to adjust this location accordingly.

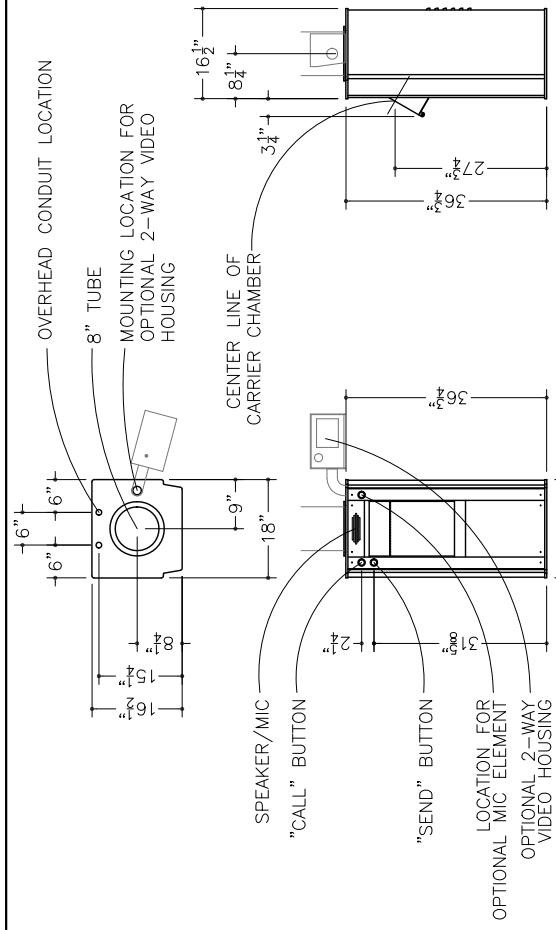

MODEL 781 CUSTOMER TERMINAL
 AVC PART #781-1800
 WEIGHT: 85 LBS.

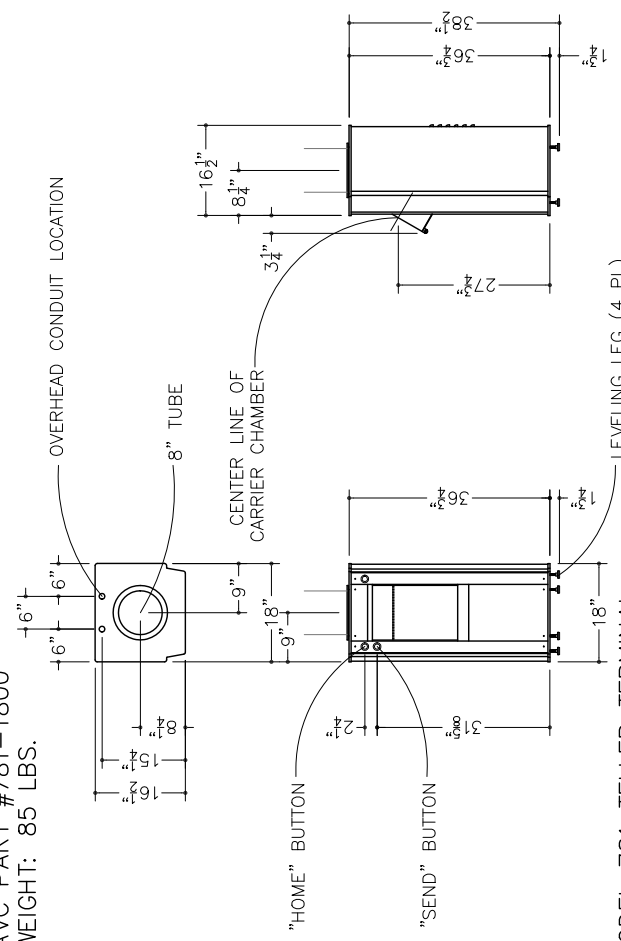

MODEL 781 TELLER TERMINAL
 AVC PART #781-2800
 WEIGHT: 85 LBS.

NOTES:
 1. ORDER ADDITIONAL AS REQUIRED.

A/R	EA	2007-0004	CABLE,4 COND,22AWG,1000' SPOOL	1
A/R	EA	2007-0020	CABLE,3 PR,SHIELDED,1000' SPOOL	1
A/R	EA	2009-0003	CABLE,15 COND,22 AWG,1000' SPOOL	1
A/R	EA	9033-0007	STRAP CLAMP,8"	1
A/R	EA	9033-0004	STL BEND,8x32	1
ADDITIONAL ITEMS REQUIRED DEPENDING ON JOB CONDITIONS				

2	EA	9033-0008	COMPRESSION COUPLING, 8" x 8"	1
2	EA	9033-0002	STL BEND w/AIR PORT,8"x32"	1
2	EA	9033-0001	STL TUBE,8"x16 Gax10' LG.	1
1	EA	2275-0004	HOSE, 3"x25' LG	1
4	EA	700-9911	CONDUIT,3/4"MCx10" (POWDER COATED)	
2	EA	781-9182	CEILING TRANSITION TRIM	
1	EA	781-9153	COUNTER-TOP TRIM	
2	EA	781-4100	PIPE SADDLE KIT ASSY,8x3	
1	EA	781-1700	INSTALLATION HARDWARE KIT ASSY	
2	EA	781-4000	AIR HANDLER ASSY	
1	EA	781-5200	CARRIER ASSY, 8" SIDE OPENING	
1	EA	781-1800	CUSTOMER TERMINAL ASSY	
1	EA	781-2800	TELLER TERMINAL ASSY	
QTY	UOM	PART NO.	DESCRIPTION	NOTE
MODEL 781-01 COMMERCIAL TRANSPORT SYSTEM				
INCLUDES THE ABOVE				

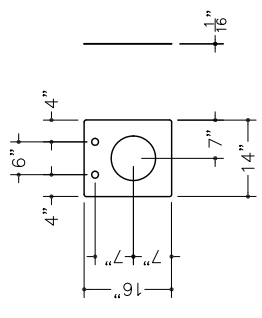

CEILING TRANSITION TRIM
 AVC PART #781-9182

DO NOT SCALE

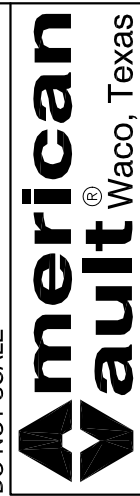

Waco, Texas

PRODUCT APPLICATION DRAWING

700 SERIES 8" COMMERCIAL TRANSPORT SYSTEM

MODEL 781-01

COMPONENT DETAILS

SIZE	DWG NO	DATE	SHEET
B	20142	10.13.05	1 OF 3

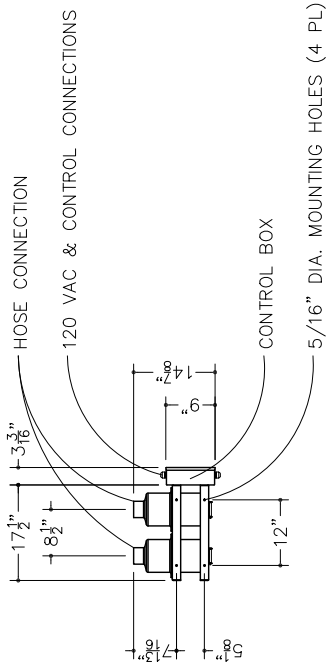

AIR HANDLER ASSY
 AVC PART #781-4000
 WEIGHT: 25 LBS.

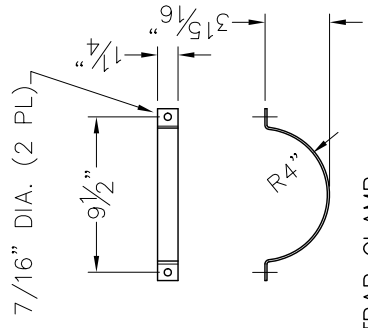

STRAP CLAMP
 AVC PART #9033-0007
 WEIGHT: 1 LBS.
 (REQUIRES 2 FOR COMPLETE CLAMP)

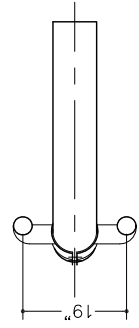

STL BEND, 8x32
 AVC PART #9033-0004
 WEIGHT: 30 LBS.

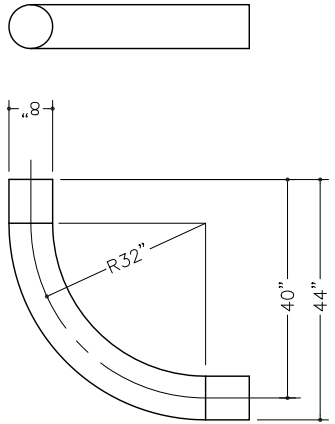

STL BEND w/AIR PORT, 8x32
 AVC PART #9033-0002
 WEIGHT: 30 LBS.

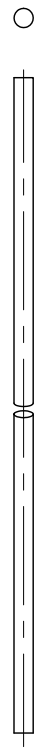

HOSE, 3" x 25'
 AVC PART #2275-0004
 WEIGHT: 30 LBS.

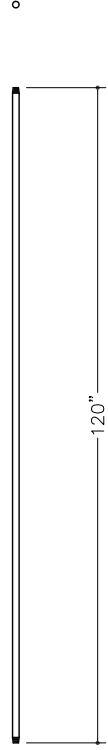

CONDUIT, 3/4" IMC x 10' (POWDER COATED)
 AVC PART #700-9911
 WEIGHT: 12 LBS.

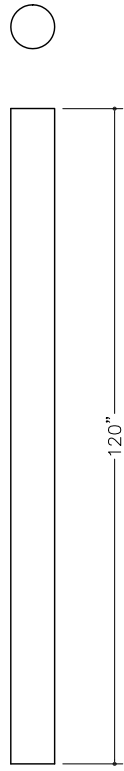

STL TUBE, 8" x 16 GA x 10' LG
 AVC PART #9033-0001
 WEIGHT: 50 LBS.

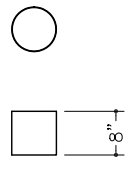

COMP CPLG, 8" x 8" LG.
 AVC PART #9033-0008
 WEIGHT: 15 LBS.

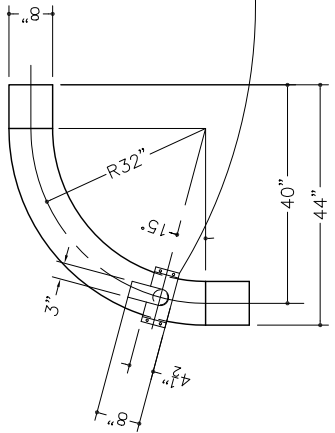

PIPE SADDLE KIT ASSY, 8x3
 AVC PART #781-4100

DO NOT SCALE

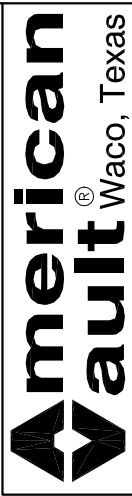

PRODUCT APPLICATION DRAWING		SHEET
700 SERIES 8" COMMERCIAL TRANSPORT SYSTEM		2 OF 3
MODEL 781-01		
COMPONENT DETAILS		
SIZE	DWG NO	DATE
B	20142	10.13.05

2 INSTALLATION (continued)

2.6 Installation Procedure

2.6.1 Teller Terminal

Survey the area where the T/T will be installed. There are serviceable components inside the unit and it will be necessary to remove the case sides to gain access. If this is not possible it will be necessary to remove the unit from under the counter to service. The teller unit is installed under the counter with the tube and conduit protruding through a notch in the counter-top. It is trimmed using the counter-top trim provided.

1. Using the Counter-top trim as a guide, trace the outline and cut a notch (12-1/2" x 16-1/4") in the counter. Refer to figure 2-1 drawing #20142.
2. Install (4) levelers provided in the frame base plate. Screw these in all the way. They will be adjusted for level at a later time.
3. Using (2) 8-32 x 5/16 TPHMS screws provided mount the counter-top trim mounting bracket to the Frame Top Plate. Install (2) 8-32 clip nuts provide onto the trim mounting bracket.
4. Temporarily mount the counter-top trim using (2) 8-32 x 1/2 TPHMS provided.
5. Slide the unit under the counter until the counter-top trim is flush with the counter front edge.
6. Adjust the levelers up until the frame top plate is flush against the bottom side of the counter making sure the unit is level. The counter top trim is 1-3/4" thick and will protrude above most counters by approximately 1/4". It important that there is a space under the frame base plate in order to facilitate the removal of the unit at a later date for service.

2.6.2 Customer Terminal

It is important to survey the area the C/T will be installed in. There are serviceable components inside the unit and it will be necessary to remove the front panel, case sides and rear panel to gain access.

1. Position the C/T on the island. Refer to figure 2-1 drawing # 20142 for the recommended location.
2. Remove the front panel and place beside the unit. Do not remove any wires.
3. Remove the case sides and case rear.
4. Locate the (4) 1/2" dia. holes in the frame base plate. Transfer the locations to the island.
5. Move the C/T out of the way.
6. Using a masonry bit, drill (4) 3/8" dia. holes and install the (4) 3/8" x 2-3/4" wedge anchors provided.
7. Position the C/T over the anchors and shim under the frame base plate as required. Check for level and secure using the nuts provided with the anchors. Re-check for level.

2 INSTALLATION (continued)

2.6.3 Tubing

When cutting tube or radii, it is imperative to have a smooth, straight cut. A rotary blade saw (such as the T-Drill Pipe and Tube cutter <http://www.t-drill.com/Pipe-Cutter.html>) or tubing cutter is the preferred method of cutting. If using a reciprocating blade saw, make sure there are no jagged edges. All ends should be filed smooth.

Tube and radii joints should be a tight butt joint. There should be no gaps between successive tube ends. A gap in the joint will allow the carrier accelerator disc to hang in the joint and cause premature wear or not operate. Joints should be secured by compression couplings or flanging to prevent vacuum loss.

Tubing should be braced to prevent excessive movement and stresses at the joints. Tubing should be supported approximately 24" from each end with no more than 6' between supports.

1. Remove counter-top trim, seal retainer and o-ring from top of unit.
2. Using a plumb bob or other means locate the center of tubing in the top of the unit. Project this center up through the ceiling or soffit where the tube will penetrate.
3. Using the ceiling transition trim as a template cut a hole in the ceiling or soffit for the tube and (2) holes for conduit.
4. Locate where the horizontal tube will run.
5. Temporarily install the radius allowing space for it to be adjusted in all directions. Adjust the radius so the center of the radius lines up with the center of the tube in the top of the unit. Make note of the orientation of the air port in the radius.
6. Measure and cut a piece of tubing that goes from the top of the unit to lower end of radius. When measuring make sure you measure to the tube recess in the frame top plate. Do not install tubing at this time.
7. Measure and cut (2) pieces of ¾" IMC powder coated conduit. This should be long enough to go through ceiling or soffit by approximately 6".
8. Slip compression coupling, ceiling transition trim, counter-top trim, seal retainer and o-ring onto tube. Temporarily secure compression coupling on tube, so it will not slip.
9. Position tube into recess in top of unit and through hole in ceiling or soffit previously cut. Position o-ring in groove, install seal retainer using (5) SHCS 8-32 x ½" provided.
10. Pass (2) conduit through holes in ceiling transition trim and into holes in counter-top trim. Thread into top of T/T using soft jawed tools to prevent tool from marring finish.
11. Secure counter-top trim to mounting bracket previously installed.
12. Adjust radius to mate with the top of the tube and secure.
13. Position the compression coupling at the joint between the tube and the radius and secure. The coupling is 8" long and should be positioned so tube joint is centered in the coupling. (Installation tip: Put a mark on tube at 4" from the end so you will know when it is centered.)
14. Position and install pipe saddle assembly onto radius as shown in figure 2-1 (drawing #20142).
15. Repeat steps 1 through 14 at opposite end.
16. Proceed with installation of horizontal tube. Position a compression coupling over the end of the previously installed radius or tube. Loosely secure tube to structure so it can be moved and adjusted as needed. Position and align end of tube to previously installed radius or tube. Slide coupling into position and secure. Permanently secure tube to structure before proceeding to next length of tube or radius.

2 INSTALLATION (continued)

2.6.4 Air Handlers

1. Install Air Handlers in the canopy above the soffit line in close proximity to the radius directly above the units. If job site conditions allow position the air handler at the teller end just outside the exterior wall. The air handlers weigh approximately 25 lbs. each and need to be secured in a manner that will not allow them vibrate loose. There is a 25' length of 3" hose supplied with each system that is to be used for the connection between the air handler nozzle and the pipe saddle. This is sufficient provided that the air handlers are located no more than 6' from the pipe saddle on the radius.
2. Measure and cut (4) pieces of 3" hose provided.
3. Install hose using (8) hose clamps provided.

2.6.5 Electrical and Control (Refer to figure 2-2 drawing #781-1001-01)

#	DATE	REVISION	NAME
A	10.19.2005	NEW DWG. RELEASED FOR PRODUCTION	CB
	10.19.05		

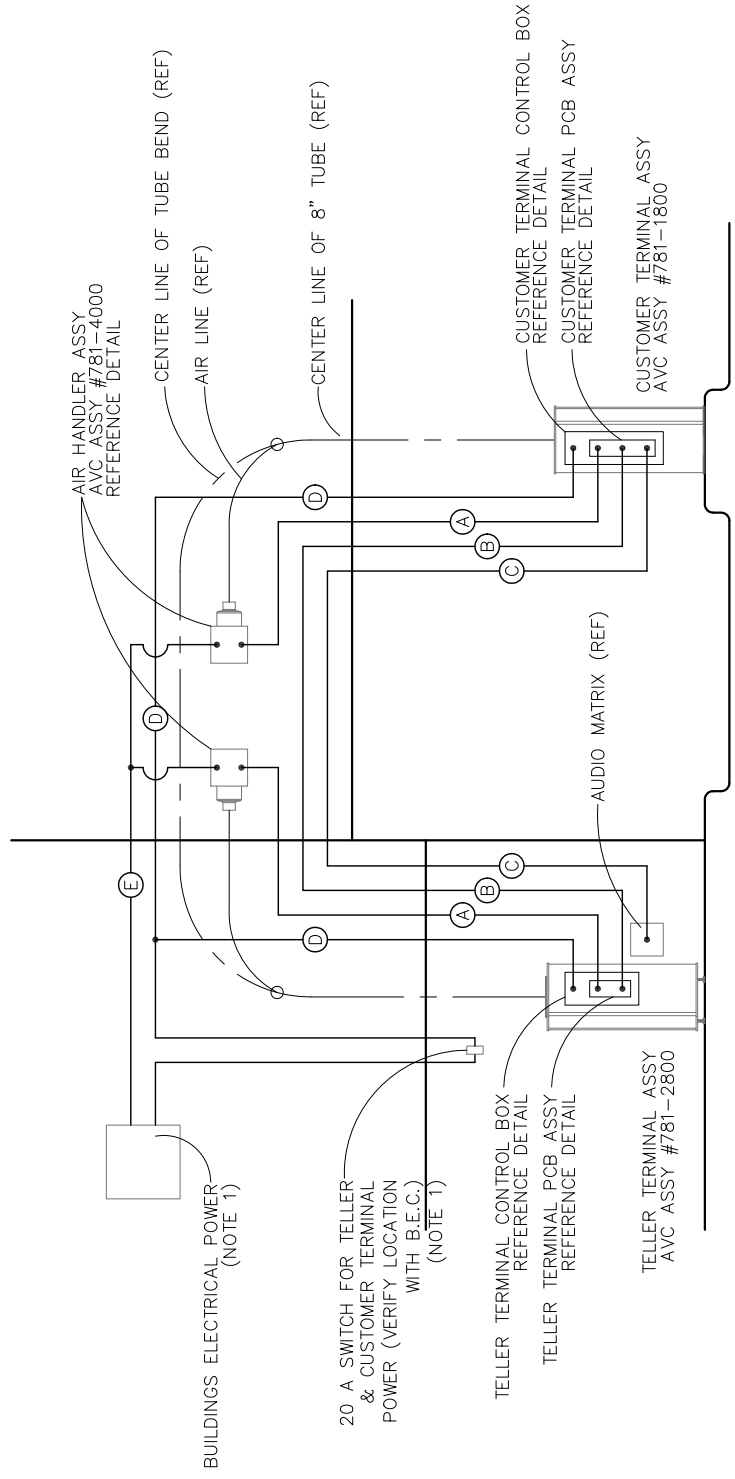

- (A) AIR HANDLER INTERFACE CABLE
4 CONDUCTOR, 22 GA.
REF. BELDEN #8444 OR EQUIV.
AVC PART #2007-0004
- (B) CUSTOMER/TELLER INTERFACE CABLE
15 CONDUCTOR, 22GA.
REF. BELDEN #8456 OR EQUIV.
AVC PART #2009-0003
- (C) AUDIO INTERFACE CABLE
3 PR INDIVIDUALLY SHIELDED, 22 GA
REF. BELDEN #8777 OR EQUIV.
AVC PART #2007-0020
- (D) 120 VAC, 60Hz, 1PH, 20 AMP
DEDICATED SWITCHED BRANCH CIRCUIT
(NOTE 1)
- (E) 120 VAC, 60Hz, 1PH, 30 AMP
DEDICATED BRANCH CIRCUIT
(NOTE 1)

NOTES:
1. THE BRANCH CIRCUITS SUPPLYING THE MODEL 781 CTS AND AIR HANDLERS MUST BE DEDICATED CIRCUITS USING INDIVIDUAL HOT, NEUTRAL AND GROUND CONDUCTORS. NEITHER THE CONDUIT NOR THE NEUTRAL SHOULD BE SHARED WITH OTHER CIRCUITS.

DO NOT SCALE	
FILE NAME N:\DRAWINGS\781\781-1001-01.dwg	
DRAWN 10.19.05	
CHECK	
DESCRIPTION SYSTEM WIRING DIAGRAM MODEL 781-01 8" CTS	
SIZE DWG NO	REV SCALE
B 781-1001-01	A 1:1
SHEET 1 OF 2	

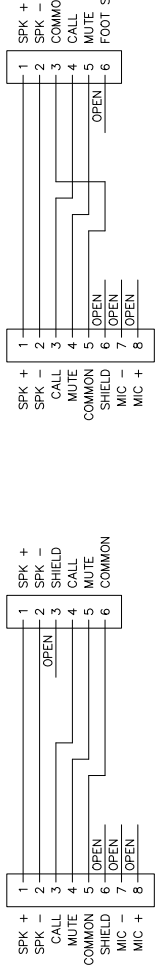
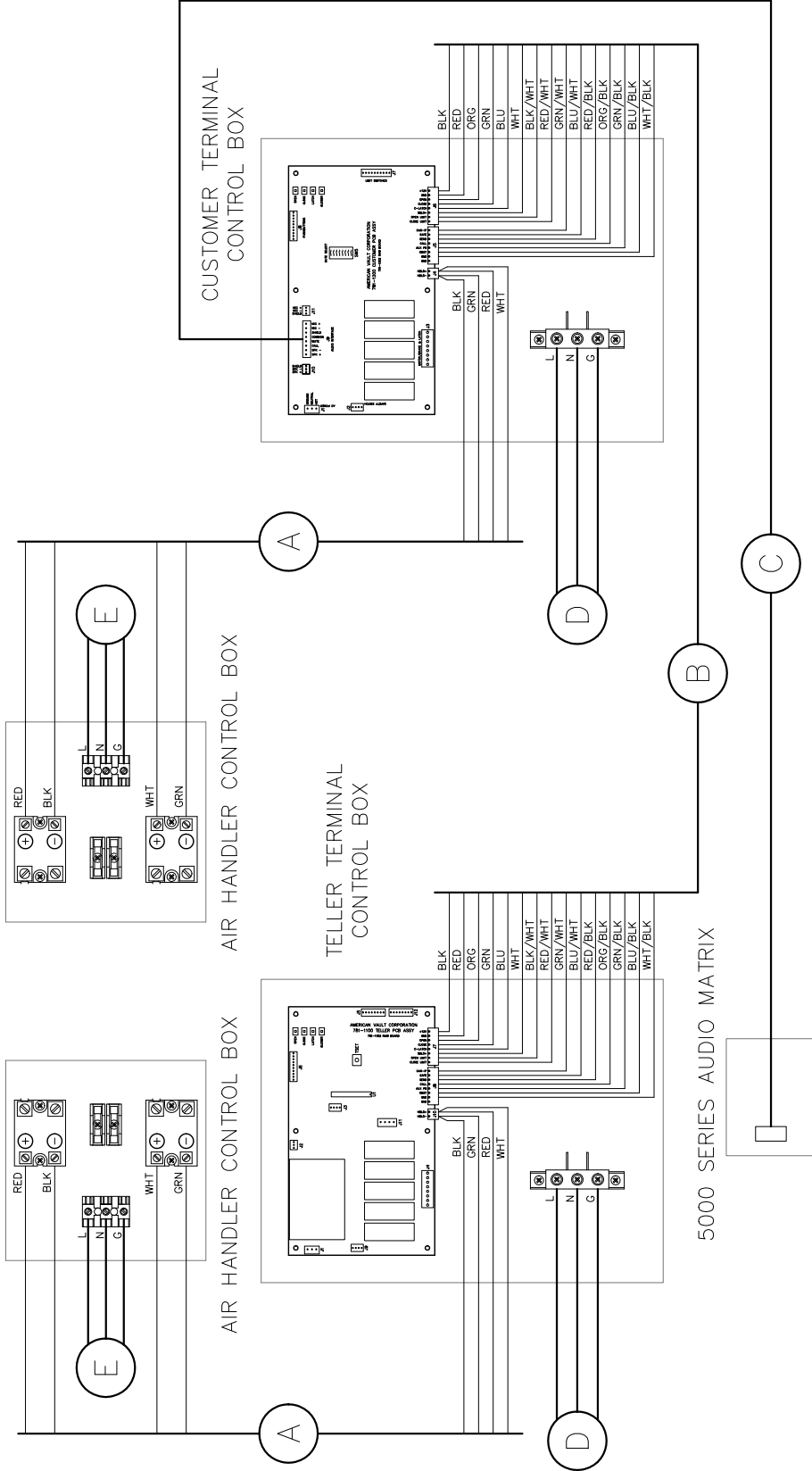

DO NOT SCALE		DESCRIPTION
FILE NAME N:\DRAWINGS\781\781-1001-01.dwg	SYSTEM WIRING DIAGRAM	
DRAWN CB	REV A	MODEL 781-01 8" CTS
CHECK	DWG NO 781-1001-01	SCALE 1:4
SIZE B		SHEET 2 OF 2

American
Waco, Texas

3 OPERATIONS

3.1 Switches and Indicators-Customer Terminal (C/T)

3.1.1 Open Limit Switch (SW1)

Located on the left, interior frame vertical, it is used to monitor the carrier chamber open position.

3.1.2 Open Over Travel Switch (SW2)

Located on the left, interior frame vertical, it is used as a fail-safe in the event the open limit switch fails.

3.1.3 Close Limit Switch (SW3)

Located on the right, interior frame vertical, it is used to monitor the carrier chamber closed position.

3.1.4 Close Over Travel Switch (SW4)

Located on the right, interior frame vertical, it is used as a fail-safe in the event the close limit switch fails.

3.1.5 Carrier Present Switch (SW6)

Located below the carrier chamber, it is used to monitor the carrier location.

3.1.6 Send Switch & Lamp (SW7)

Located on the upper, left of the front panel, pressing initiates a send cycle and is only operable when the carrier is present in the chamber.

3.1.7 Call Switch & Lamp (SW10)

Located on the upper, left of the front panel, it is part of the audio interface provided on the C/T circuit board. Pressing this switch generates a call tone on the connected audio system.

3.1.8 Safety Edge Switch (Door Obstruct) (SW11)

Located on the upper, front edge of the carrier chamber, indicates the presence of an obstruction in the chamber opening & closing cycle.

3.1.9 Safety Edge Switch (Door Closing) (SW12)

Located on the upper, center of the front panel, below the speaker grill, it interfaces with the circuit board to monitor the presence of obstructions.

3.2 Devices-Customer Terminal (C/T)

3.2.1 Speaker (SPK1)

Located on the upper, center of the front panel, is part of the audio interface provided on the C/T circuit board. When the connected audio system generates a sound it is projected through the speaker. When connected to the AVC ICE audio system it also functions as a microphone, generating sounds produced by the customer.

3.2.2 C/T PCB Assembly

Located inside the electrical enclosure in the lower, center of the C/T, It is used to control and monitor functions at the C/T.

3.2.3 Motor Run Capacitor

Located on the back of the electrical enclosure.

3.2.4 Gear Motor and Brake (M1)

Located behind the electrical enclosure, mounted to the frame vertical, it is used to drive the operating mechanism.

3 OPERATIONS (continued)

3.2 Devices-Customer Terminal (C/T) (continued)

3.2.5 Chamber Latch Solenoid

Located under the chamber, it is used to latch the valve in the bottom of the chamber.

3.2.6 Chamber Valve

Located in the bottom of the chamber, it is used to control the air flow into the chamber.

3.2.7 Terminal Block (TB1)

Located inside the electrical enclosure, it is the terminal block used for the primary electrical service.

3.2.8 Fuse (F1)

Located inside the electrical enclosure.

3.3 Switches and Indicators-Teller Terminal (T/T)

3.3.1 Open Limit Switch (SW1)

Located on the left, interior frame vertical, it is used to monitor the carrier chamber open position.

3.3.2 Open Over Travel Switch (SW2)

Located on the left, interior frame vertical, it is used as a fail-safe in the event the open limit switch fails.

3.3.3 Close Limit Switch (SW3)

Located on the right, interior frame vertical, it is used to monitor the carrier chamber closed position.

3.3.4 Close Over Travel Switch (SW4)

Located on the right, interior frame vertical, it is used as a fail-safe in the event the close limit switch fails.

3.3.5 Carrier Present Switch (SW6)

Located below the carrier chamber, it is used to monitor the carrier location.

3.3.6 Send Switch & Lamp (SW7)

Located on the upper, left of the front panel, pressing initiates a send cycle and is only operable when the carrier is present in the chamber.

3.3.7 Home Switch & Lamp (SW8)

Located on the upper, left of the front panel.

3.3.8 Door Switch & Lamp (SW9)

Located on the upper, right of the front panel.

3.3.9 Safety Edge Switch (Door Obstruct) (SW11)

Located on the upper, front edge of the carrier chamber, indicates the presence of an obstruction in the chamber opening & closing cycle.

3.3.10 Safety Edge Switch (Door Closing) (SW12)

Located on the upper, center of the front panel, below the speaker grill, it interfaces with the circuit board to monitor the presence of obstructions.

3 OPERATIONS (continued)

3.4 Devices-Teller Terminal (T/T)

3.4.1 T/T PCB Assembly

Located inside the electrical enclosure in the lower, center of the T/T, It is used to control and monitor functions at the T/T.

3.4.2 Motor Run Capacitor

Located on the back of the electrical enclosure.

3.4.3 Gear Motor and Brake (M1)

Located behind the electrical enclosure, mounted to the frame vertical, it is used to drive the operating mechanism.

3.4.4 Chamber Latch Solenoid

Located under the chamber, it is used to latch the valve in the bottom of the chamber.

3.4.5 Chamber Valve

Located in the bottom of the chamber, it is used to control the air flow into the chamber.

3.4.6 Terminal Block (TB1)

Located inside the electrical enclosure, it is the terminal block for the primary electrical service.

3.4.7 Fuse (F1)

Located inside the electrical enclosure.

3.5 Devices-Air Handler (A/H)

3.5.1 Fuse (F1)

Located in the A/H electrical enclosure, it protects the motor circuit.

3.5.2 Fuse (F2)

Located in the A/H electrical enclosure, it protects the motor circuit.

3.5.3 Relay (KY1)

Located in the A/H electrical enclosure, it controls the on-off state of Motor (M1).

3.5.4 Relay (KY2)

Located in the A/H electrical enclosure, it controls the on-off state of Motor (M2).

3.5.6 Motor (M1)

Mounted to the A/H motor mount and concealed by the motor housing, it is used to pull a vacuum on the system.

3.5.7 Motor (M2)

Mounted to the A/H motor mount and concealed by the motor housing, it is used to pull a vacuum on the system.

3.5.8 Terminal Block (TB1)

Located in the A/H electrical enclosure, it is the terminal block for primary electrical service.

3 OPERATIONS (continued)

3.6 Functions

3.6.1 Teller Terminal

Send

This function moves the carrier from the T/T to the C/T. Send is only accessible if the carrier is located in the T/T chamber as indicated by the send pushbutton light being on. Press the T/T send pushbutton to initiate the send function. The control will first close both chamber doors then latch the C/T chamber valve. Both air handlers will turn on. After 1 second, the T/T air handler will turn off and the C/T air handler will continue to run until the carrier arrives at the C/T or the blower's time out. Lastly, the C/T chamber will open and present the carrier to the customer. If the blower's time out, the system will enter recovery mode which will allow additional time (10 sec.) for the carrier to arrive at the C/T then if it fails, will recall the carrier to the T/T and open the chamber.

Home

This function moves the carrier from the C/T to the T/T. Home is only accessible if the carrier is located in the C/T chamber as indicated by the T/T home pushbutton light being on. Press the T/T Home pushbutton to initiate the send function. The control will first close both chamber doors then latch the T/T chamber valve. Both air handlers will turn on. After 1 second, the C/T air handler will turn off and the T/T air handler will continue to run until the carrier arrives at the T/T or the blower's time out. Lastly, the T/T chamber will open and present the carrier to the teller. If the blower's time out, the system will enter recovery mode which will allow additional time (10 sec.) for the carrier to arrive at the T/T then if it fails, will recall the carrier to the C/T and open the chamber.

Door

This function toggles the chamber open or closed on the end where the carrier is in the chamber. If the chamber is open, pressing the Door pushbutton closes it. If the chamber is closed, pressing the Door pushbutton opens it.

Door toggle without carrier

This function allows the operator to change the position of the C/T and T/T chambers when a carrier is not present. Pressing Door in combination with the Send pushbutton toggles the C/T chamber. Pressing Door in combination with Home toggles the T/T chamber.

Clear Fault

If either chamber opens onto a foreign object and contacts the obstruction safety bar, the system will enter a fault mode indicated by both the send pushbutton light and the home pushbutton light on the T/T flashing simultaneously. Before clearing this fault the operator must find the cause of the obstruction and remove it. To clear the fault in the system, the operator should press Door and Send at the same time and the unit will revert to normal operation.

Shutdown Mode

To prepare the system for overnight standby, home the system and remove the carrier. Then press the door and home pushbuttons. This will close the teller chamber and seal the system. To return the system to service, press the door and home pushbuttons. The chamber will open, replace the carrier and the system is ready for use.

3 OPERATIONS (continued)

3.6 Functions (continued)

3.6.2 Customer Terminal

Send

C/T send functions just like home above except that it is ignored if the C/T chamber is closed.

Call

Call is connected to the audio interface and triggers the audio system to alert the teller that a customer is present. It has no other function in the system.

4 MAINTENANCE

4.1 Cleaning

The customer and teller units should be cleaned with a mild cleaner and a soft cloth. Any debris should be removed from the carrier deposit chambers as they could prevent proper operation of the system. Use of harsh solvents or acids could damage the finish of the system.

4.2 Preventative maintenance.

There are no user serviceable parts in the customer or teller units and all service should be performed by authorized service personnel. The system should be serviced yearly to check the condition of drive components, and to remove any debris from the inside of the customer and teller units. The serviceman should check the motor, drive mechanism, limit switch assemblies and latches signs of excessive wear, and replace if necessary.

5 SERVICE (Refer to Figures 5-1, 5-2, 5-3, 5-4 & 5-5)

5.1 Service Functions-Teller Terminal (Refer to figure 5-5)

PCB pushbuttons located near the upper right corner of the T/T PCB assembly are:

SW1 Chamber Open

SW2 Chamber Close

SW3 Latch Engage

SW4 Home Blowers On

SW5 TSET (located right center on PCB)

Open

The open switch SW1 opens the T/T chamber until it reaches the open limit switch. While pressed, the TTO led will light and when the open limit is reached, the TTOL led should light.

Close

The close switch located on the T/T PCB, SW2, closes the T/T chamber until it reaches the close over travel switch. While pressed, the TTC led will light and when the open limit is reached, the TTCL led should light.

Latch

The latch switch, SW3, engages the latch that locks the air valve in the bottom of the chamber.

Blowers

The blower switch, SW4 activates the air handler above the T/T.

5.1 Service Functions-Teller Terminal (continued)

TSET

The TSET switch, SW5 initiates a TSET operation that sets the blower run times for the system. The system startup procedure should be completed prior to running TSET.

Cycle Test

The cycle test mode should not be used until the system is completely in operation and the TSET procedure has been successfully completed, otherwise an unknown time may be stored in the controller. To enter the cycle test mode, the technician must hold the TSET switch SW5 while applying 120 VAC power to the teller PCB. This is done by unplugging the 120 Vac power connector from the board, holding the TSET switch and plugging power back in. The system takes about 10 seconds to power up and enter the cycle test mode and the TSET switch must be held until the system begins cycling. The 120 Vac power connector for the Teller PCB is the upper left hand corner of the printed circuit board. To exit the cycle test mode, power cycle the board. When power is re-applied, the system will be ready for normal operation.

5 SERVICE (continued)

5.2 Service Led's-Teller Terminal (Refer to figure 5-5)

DS1	TTO	Teller Terminal Open	Lights when either the open switch (sw1) is pressed or when the teller controller is opening the chamber.
DS2	TTC	Teller Terminal Close	Lights when either the close switch (sw2) is pressed or when the teller controller is closing the chamber.
DS3	TLAT	Teller Latch	Lights when either the latch switch (sw3) is pressed or when the teller controller is latching the chamber air valve.
DS4	HBLO	Home Blowers	Lights when either the blower switch (sw4) is pressed or when the teller controller is activating the home blowers.
DS5	TTOL	Teller Terminal Open Limit	Lights when the chamber is on the open position.
DS6	TTCL	Teller Terminal Close Limit	Lights when the chamber is on the closed position.
DS7	TCAR	Teller Carrier present switch	Lights when the carrier is properly seated in the Teller carrier chamber.
DS8	TSAF	Teller Safety Bar safe circuit	Normally lit unless there is a fault in the safety bar circuit
DS9	TSND	Teller Send	Lights when the Teller Send pushbutton is pressed.
DS10	HOME	Teller Home	Lights when the Teller Home pushbutton is pressed
DS11	TDOR	Teller Door	Lights when the Teller Home pushbutton is pressed
DS12	OBST	Obstruction	Lights when the safety bar located on the front edge of the chamber is pressed.

5.3 Service Functions-Customer Terminal (Refer to figure 5-4)

Open

The open switch SW1 opens the C/T chamber until it reaches the open limit switch. While pressed, the CTO led will light and when the open limit is reached, the CTOL led should light.

Close

The close switch located on the C/T PCB, SW2, closes the C/T chamber until it reaches the close over travel switch. While pressed, the CTC led will light and when the open limit is reached, the CTCL led should light.

Latch

The latch switch, SW3, engages the latch that locks the air valve in the bottom of the chamber

Blowers

The blower switch, SW4 activates the air handler above the C/T

5 SERVICE (continued)

5.4 Service Led's-Customer Terminal (Refer to figure 5-4)

DS1	CTO	Teller Terminal Open Lights when either the open switch (sw1) is pressed or when the Customer controller is opening the chamber.
DS2	CTC	Customer Terminal Close Lights when either the close switch (sw2) is pressed or when the Customer controller is closing the chamber.
DS3	CLAT	Customer Latch Lights when either the latch switch (sw3) is pressed or when the Customer controller is latching the chamber air valve.
DS4	SBLO	Send Blowers Lights when either the blower switch (sw4) is pressed or when the Customer controller is activating the send blowers.
DS5	CTOL	Customer Terminal Open Limit Lights when the chamber is on the open position.
DS6	CTCL	Customer Terminal Close Limit Lights when the chamber is on the closed position.
DS7	CCAR	Customer Carrier present switch Lights when the carrier is properly seated in the Customer carrier chamber.
DS8	CSAF	Customer Safety Bar safe circuit Normally lit unless there is a fault in the safety bar circuit
DS9	CSND	Customer Send Lights when the Customer Send pushbutton is pressed.
DS10	CALL	Customer Home Lights when the Customer Home pushbutton is pressed
DS11	TDOR	Not Implemented
DS12	OBST	Obstruction Lights when the safety bar located on the front edge of the chamber is pressed.

5 SERVICE (continued)

5.5 Field Wiring

Right side 8 pin connector (J7 on T/T) (J6 on C/T) (Refer to figure 5-1, 5-2, 5-4, 5-5)

+12V

Power generated on teller board and provided to customer board.

GND

Common

OPEN

Normally 0 Vdc, a positive voltage nominally 3.0 volts will open the customer chamber

CLOSE

Normally 0 Vdc, a positive voltage nominally 3.0 volts will close the customer chamber

C-LATCH

Normally 0 Vdc, a positive voltage nominally 4.0 volts will latch the customer air valve

SBLO+

Normally 0 Vdc, a positive voltage nominally 2.0 volts will activate the send blowers

OPEN LIMIT

Normally 11 Vdc, when the customer chamber is fully open it should be 0 Vdc

CLOSE LIMIT

Normally 11 Vdc, when the customer chamber is fully closed it should be 0 Vdc

Left side 8 pin connector (J8 on T/T) (J5 on C/T) (Refer to figure 5-1, 5-2, 5-4, 5-5)

CAR-IP

Normally 11 Vdc, when the carrier is in the customer chamber it should be 0 Vdc

SAFE

Normally 4 Vdc, when the safety bar circuit is in fault it should read 11 Vdc

SEND

Normally 11 Vdc, when the customer send pushbutton is pressed it should be 0 Vdc

CALL

Normally 11 Vdc, when the customer call pushbutton is pressed it should be 0 Vdc

AUX PB

OBST

Normally 11 Vdc, when the customer obstruction bar is pressed it should be 0 Vdc

GND

Common

GND

Common

2 pin connector on Teller unit (J10) (Refer to figure 5-2, 5-5)

HBLO+

Normally 0 Vdc, goes to 2.0 Vdc or greater to turn on home blowers

HBLO-

Common

5 SERVICE (continued)

5.5 Field Wiring (continued)

2 pin connector on Customer unit (J4) (Refer to figure 5-1, 5-4)

SBLO+

Normally 0 Vdc, goes to 2.0 Vdc or greater to turn on send blowers

SBLO-

Common

Air Handler field wiring (Refer to figure 5-1, 5-2, 5-3, 5-4, 5-5)

KY1-3 (+)

Control input, connects to HBLO+ or SBLO+. A positive DC voltage on this input will turn the relay on as indicated by a green led near the 4(-) terminal on the face of the relay.

KY1-4 (-)

Common, connects to HBLO- or SBLO-

KY2-3 (+)

Control input, connects to HBLO+ or SBLO+. A positive DC voltage on this input will turn the relay on as indicated by a green led near the 4(-) terminal on the face of the relay.

KY2-4 (-)

Common, connects to HBLO- or SBLO-

5.6 Audio Wiring (J9) (Refer to figure 5-1, 5-4)

SPK+ Connection to 8 ohm Speaker or Speaker/Mic

SPK- Speaker Common & Shield

CALL Switch closure to common for audio call circuit

MUTE Open collector output to Audio Mute Circuit

COMMON Common for Call and Mute

SHIELD Shield for Microphone only

MIC+ Mic + to Audio system (no microphone installed on 781 C/T base system)

MIC- Mic – to Audio system

5.7 Audio Mute selector (SW5) (Refer to figure 5-1, 5-4)

OPEN Switch SW5-1 on to mute audio during Open operation

CLOSE Switch SW5-2 on to mute audio during Close operation

BLOWER Switch SW5-3 on to mute audio during Blower operation

LATCH Switch SW5-4 on to mute audio during Latch operation

BRAKE Switch SW5-5 on to mute audio during Brake operation

5 SERVICE (continued)

5.8 Flash Indicators (Refer to figure 1-2)

The teller send and home pushbuttons will flash under different fault conditions.

These flash codes are explained below.

Simultaneous flash

The system will flash the send and home teller pushbuttons for a few seconds on power-up if the carrier is not in the system. The system will also flash simultaneously if the carrier does not arrive at the receiving end before the timeout period set using the TSET function. If this occurs the system will enter recovery mode and will return the carrier to the sending end after a delay. The system will also flash simultaneously if the Obstruction bar is activated while the chamber is opening. This fault requires an operator reset. Press and hold DOOR then press SEND and release both to clear.

Alternate flash (single)

The system will generate this flash code when the chamber safety bar is in fault. The fault must be cleared before SEND, HOME or DOOR will function. SW2, SW4 and SW5 will function in this fault.

Alternate flash (double)

The system will generate this flash code when both carrier present switches are activated. The fault must be cleared before SEND, HOME or DOOR will function. SW2, SW3, SW4 and SW5 will function in this fault.

5 SERVICE (continued)

5.9 System Startup

1. Apply power to Teller and Customer units and both Air Handlers.
2. Perform 781 teller and customer unit function tests.
3. Open teller chamber using SW2 or 'DOOR + HOME' pushbutton combination.
4. Insert empty carrier into teller chamber.
5. Press SW1 'TSET' switch and wait for cycle completion. The system should send and home the carrier without intervention.
6. Test system with 25 pounds
7. Apply pressure to top chamber safety bar while chamber is closing. This should cause the chamber to open back up. This test should be done at both teller and customer units.
8. Apply pressure to the obstruction safety bar on the chamber while opening. This should cause the system to go into fault mode and require reset 'DOOR + SEND' at the teller unit. This test should be done at both teller and customer units.
9. Reset system to clear fault
10. Test teller SEND function.
11. Test teller HOME function.
12. Test DOOR function.
 - a. If carrier is at teller end and door is closed, pressing DOOR opens teller door
 - b. If carrier is at teller end and door is open, pressing DOOR closes teller door
 - c. If carrier is at customer end and door is closed, pressing DOOR opens customer door
 - d. If carrier is at customer end and door is open, pressing DOOR closes customer door
13. Test customer SEND function.
14. Press teller SEND
15. Repeat SEND and HOME functions until satisfied with proper operation.

System is ready to place in service when all steps complete successfully.

5 SERVICE (continued)

5.10 Function Test-Customer Terminal (Refer to figure 5-4)

Symbol	Function	Test
CTO	Door Open	Press SW2, confirm door open function and DS1 Light
CTC	Door Close	Press SW3, confirm door close function and DS2 Light
CLAT	Latch	Press SW4, confirm latch engagement and DS3 Light
SBLO	Blower	Press SW5, confirm blower function and DS4 Light
CTOL	Open Limit	Move door to half way point. OL switch is the left side rear switch. Manually press open limit plunger and observe DS6. DS6 should light on first limit switch activation.
CTCL	Close Limit	Move door to halfway point. CL switch is the right side top switch. Manually press close limit plunger and observe DS6. DS6 should light on first limit switch activation.
CCAR	Carrier Present	Open door fully and manually press the carrier present switch in the bottom of the chamber. DS7 should light when the plunger is pressed. Adjustment: Place carrier in chamber and observe DS7. It should remain lit until the carrier is pulled 1/8 – 3/16 out of the chamber. If adjustment is needed, adjust set screw in plunger.
CSAF	Safety Bar	DS8 should always be lit. Pressure on the top chamber safety bar should cause DS8 to turn off.
CSND	Cust Send	Press the customer send pushbutton and DS9 should light
CALL	Cust Call	Press the customer home pushbutton and DS10 should light
TDOR	Cust Door	This function is currently not implemented
OBST	Obstruction	Apply pressure to the safety bar mounted on the chamber edge and DS12 should light.

5 SERVICE (continued)

5.11 Function Test-Teller Terminal (Refer to figure 5-5)

Symbol	Function	Test
TTO	Door Open	Press SW2, confirm door open function and DS1 Light
TTC	Door Close	Press SW3, confirm door close function and DS2 Light
TLAT	Latch	Press SW4, confirm latch engagement and DS3 Light
HBLO	Blower	Press SW5, confirm blower function and DS4 Light
TTOL	Open Limit	Move door to halfway point. OL switch is the left side rear switch. Manually press open limit plunger and observe DS5. DS5 should light on first limit switch activation (click).
TTCL	Close Limit	Move door to halfway point. CL switch is the right side top switch. Manually press close limit plunger and observe DS6. DS6 should light on first limit switch activation (click).
TCAR	Carrier Present	Open door fully and manually press the carrier present switch in the bottom of the chamber. DS7 should light when the plunger is pressed. Adjustment: Place carrier in chamber and observe DS7. It should remain lit until the carrier is pulled 1/8 – 3/16 out of the chamber. If adjustment is needed, adjust set screw in plunger.
TSAF	Safety Bar	DS8 should be lit always. Pressure on the top chamber safety bar should cause DS8 to turn off.
TSND	Teller Send	Press the teller send pushbutton and DS9 should light
HOME	Teller Home	Press the teller home pushbutton and DS10 should light
TDOR	Teller Door	Press the teller door pushbutton and DS11 should light
OBST	Obstruction	Apply pressure to the safety bar mounted on the chamber edge and DS12 should light.

5 SERVICE (continued)

5.12 Troubleshooting Guide

Symptom: Unit Will Not Power-Up	
Checks	Corrective Action
110 VAC Power	Check 110 VAC Power to teller and customer units.
12 VDC Power	Check for Send and Call pushbutton lights on the customer unit. These work directly off of 12 VDC and should always be on.
Field wiring	If the indicator light on the power supply ps1 is not lit, refer to figure 5-5, disconnect field wiring from the teller end. Power up teller end. If the power supply indicator light is now on, then there is a crossed wire or a short in the field wiring or the customer board is shorting out the 12 volt supply.
Fuses	Fuses in the teller and customer unit control boxes and in the air handler control box should be checked and replaced if defective.
Wiring	Check wiring harness on teller board and between customer and teller units.
Teller Board	Check for damaged connectors, traces or components on the teller board

Symptom: Blowers Do Not Come On	
Checks	Corrective Action
Blower Signal	Monitor the voltage on the field wiring terminals marked SBLO 'send blower' and HBLO 'home blower'. The voltage should be 0 normally and will go to at least two volts nominally when the blower signal is present
Power	Verify that blowers are connected to 110 VAC power.
Wiring	Check wiring for proper connection and continuity.
Blower Motor	Measure the AC voltage across the load side of the relay when the blower motors are not running. If this voltage is less than the 120 VAC supply voltage, the motor brushes are likely worn out. You may also check the blower motor by bypassing solid state relay and powering the motor directly. You MUST disconnect power while rewiring blower. Failure to do so could result in injury or death.
Relay indicator	The solid state relays have a green indicator led that lights when sufficient current is flowing through the input circuit to turn the relay on.
Solid State Relay	The solid state relay can be checked by the process of elimination. If you verify that the blower signal is present and verify the operation of the blower motor, it can be assumed that the relay is defective.

5 SERVICE (continued)

5.12 Troubleshooting Guide (continued)

Symptom: Customer or Teller Door Will Not Operate	
Checks	Corrective Action
Check for manual operation	Use SW1 and SW2 on the PCB to manually operate the door. If it still will not operate, check the brake
Brake	Remove the cover from the brake and observe if the actuator moves when power is supplied. If not, there may be a power problem or a defective brake . If it is actuating but not enough to release the break, then loosen the set screw in the middle of the actuator to reduce braking force.
Power	Ensure that 120 VAC power is present at the control box. this may be checked with a DVM at TB1
Capacitor	Check connections to the capacitor. Discharge the capacitor and check for a short circuit condition.
Limit Switches	Make sure that the limit switch connections are good and that the switch has continuity. Check the limit switch 'away' from the door position. If this switch is defective the door won't move to it.
Wiring	Check all wiring and connections in the limit switch and motor harness. Check closely for damaged contacts in the connectors which may appear OK but may not be making contact.
Gear motor	The motor lead resistance should be 35 Ohms nominally from black to blue/ red and 54 from yellow to blue/red. There should be no continuity from red to case, red to black or black to case. If motor is running but the output shaft is not turning, the gearbox may be defective.

Symptom: Air Valve Does Not Operate	
Checks	Corrective Action
Check valve for free movement up & down	Make sure the valve rod can be moved up & down freely. If the rod is not free, check for debris or burrs.
Latch	Using SW3 on the PCB, ensure that the latch locks the valve rod in a closed position.
Seal	Check seal on the valve disc to ensure that it is sealing the chamber properly and is not preventing the valve from closing far enough to latch.
Solenoid	Make sure the solenoid is working and adjusted properly. If the plunger cannot bottom out in the solenoid, it will vibrate excessively.
Chamber Bottom	Check chamber bottom for debris that could keep the valve from sealing properly.

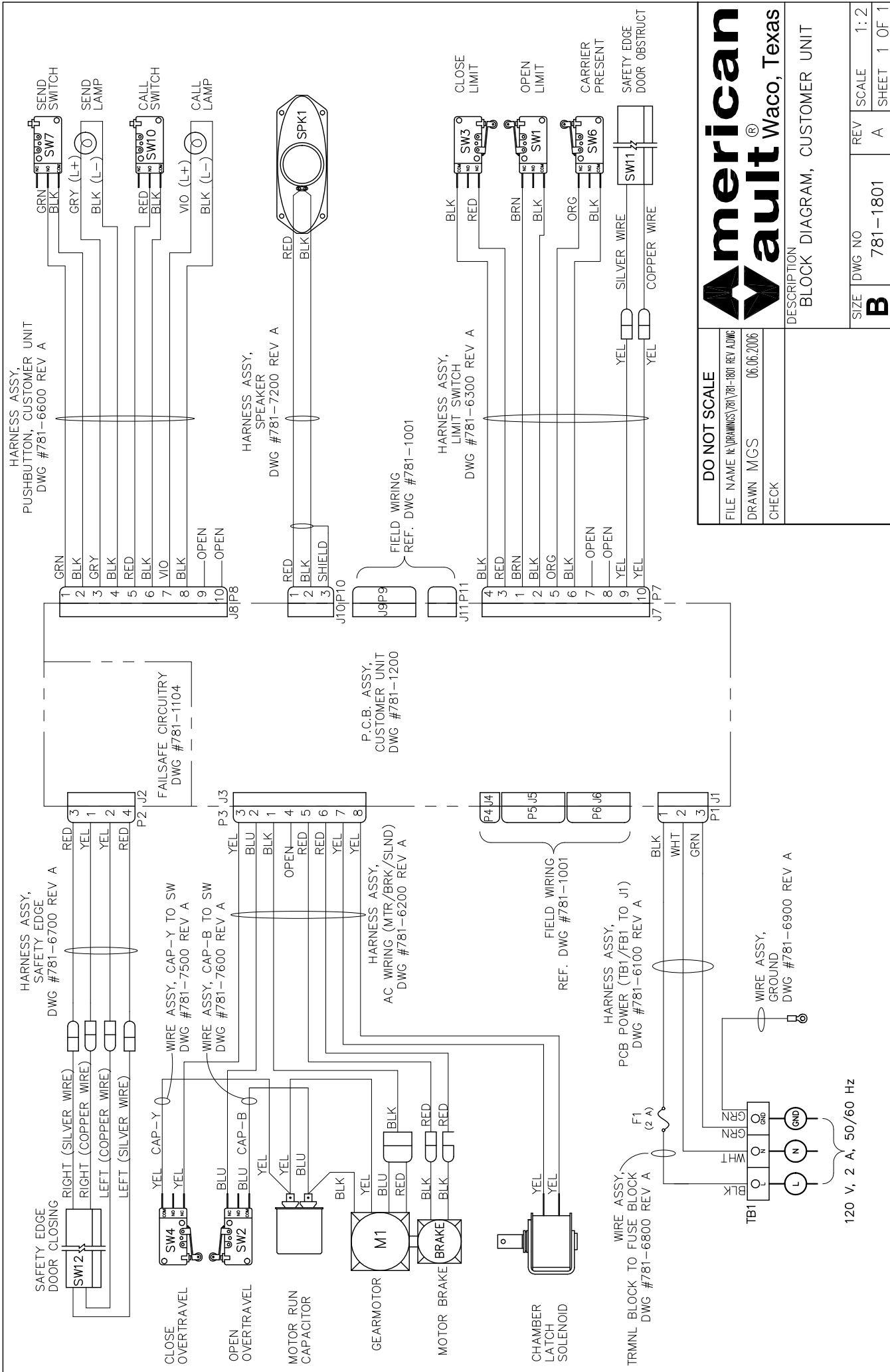

DO NOT SCALE		DESCRIPTION
FILE NAME	N:\DRAWINGS\781\781-1801 REV A.DWG	BLOCK DIAGRAM, CUSTOMER UNIT
DRAWN	MGS	06.06.2006
CHECK		
SIZE	DWG NO	REV
B	781-1801	A
		SCALE
		1:2
		SHEET
		1 OF 1

American
Waco, Texas

DESCRIPTION
BLOCK DIAGRAM, CUSTOMER UNIT

120 V, 2 A, 50/60 Hz

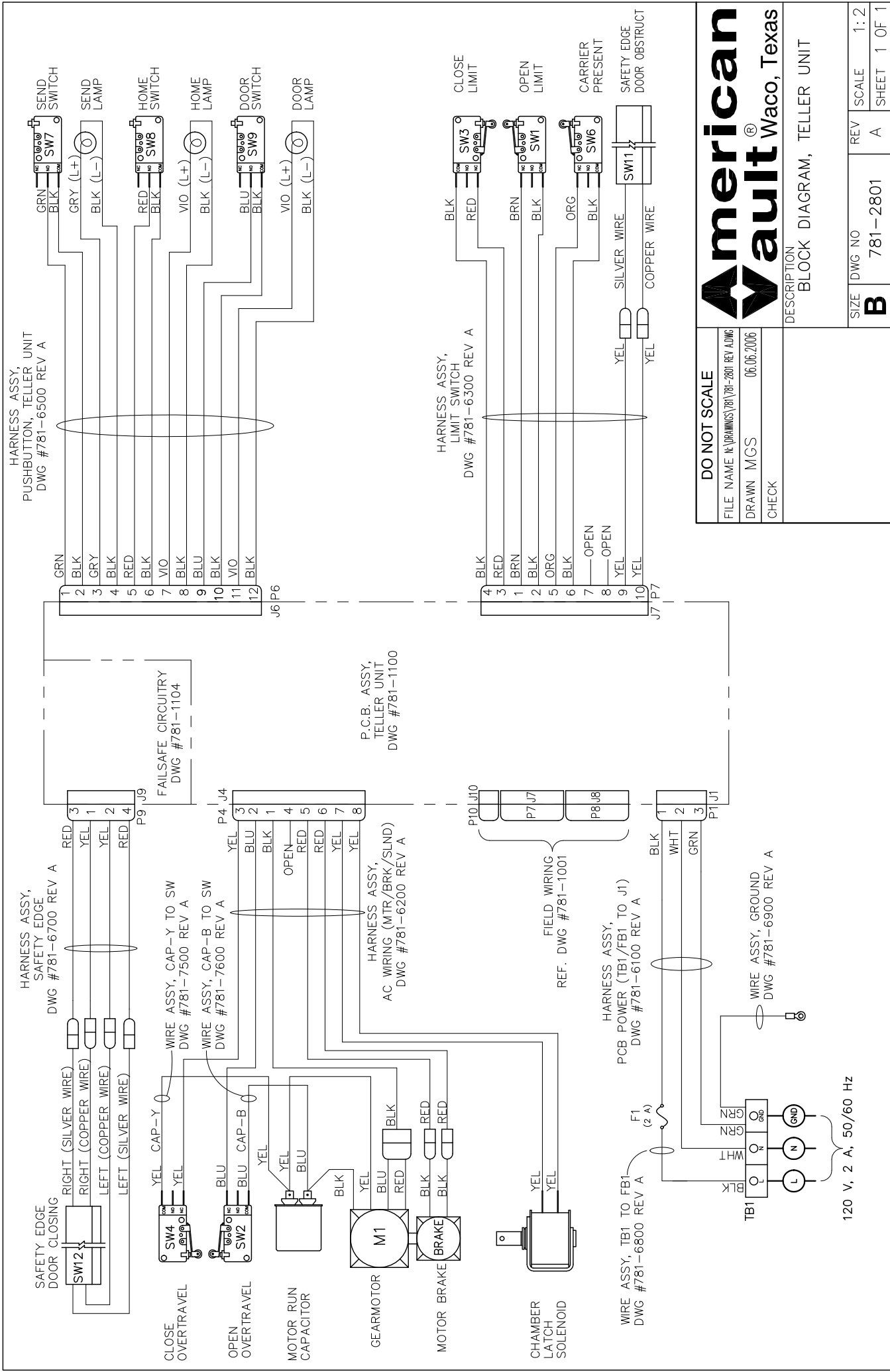

DO NOT SCALE		REV	SCALE	1:2
FILE NAME: \DRAWINGS\781\781-2801 REV ADJWG	DRAWN	MGS	06.06.2006	
CHECK				
DESCRIPTION BLOCK DIAGRAM, TELLER UNIT				
SIZE	DWG NO	REV	SCALE	1:2
B	781-2801	A		1 OF 1

American Waco, Texas

120 V, 2 A, 50/60 Hz

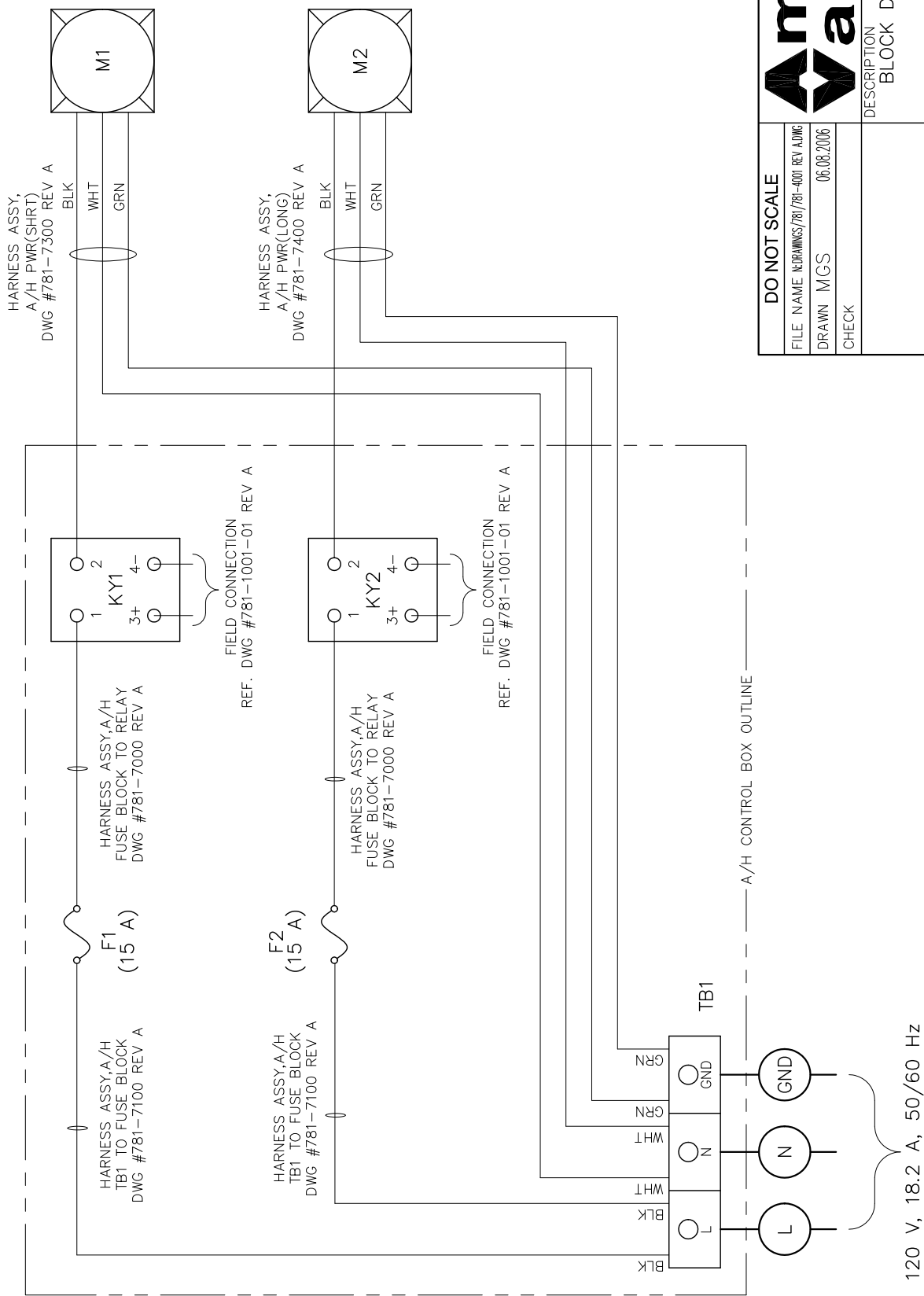

DO NOT SCALE		DESCRIPTION
FILE NAME	NCDRAWINGS/781/781-4001 REV ADWG	BLOCK DIAGRAM, AIR HANDLER
DRAWN	MGS	REV
CHECK		SCALE
	06.08.2006	1:1
SIZE	DWG NO	REV
B	781-4001	A
		SHEET
		1 OF 1

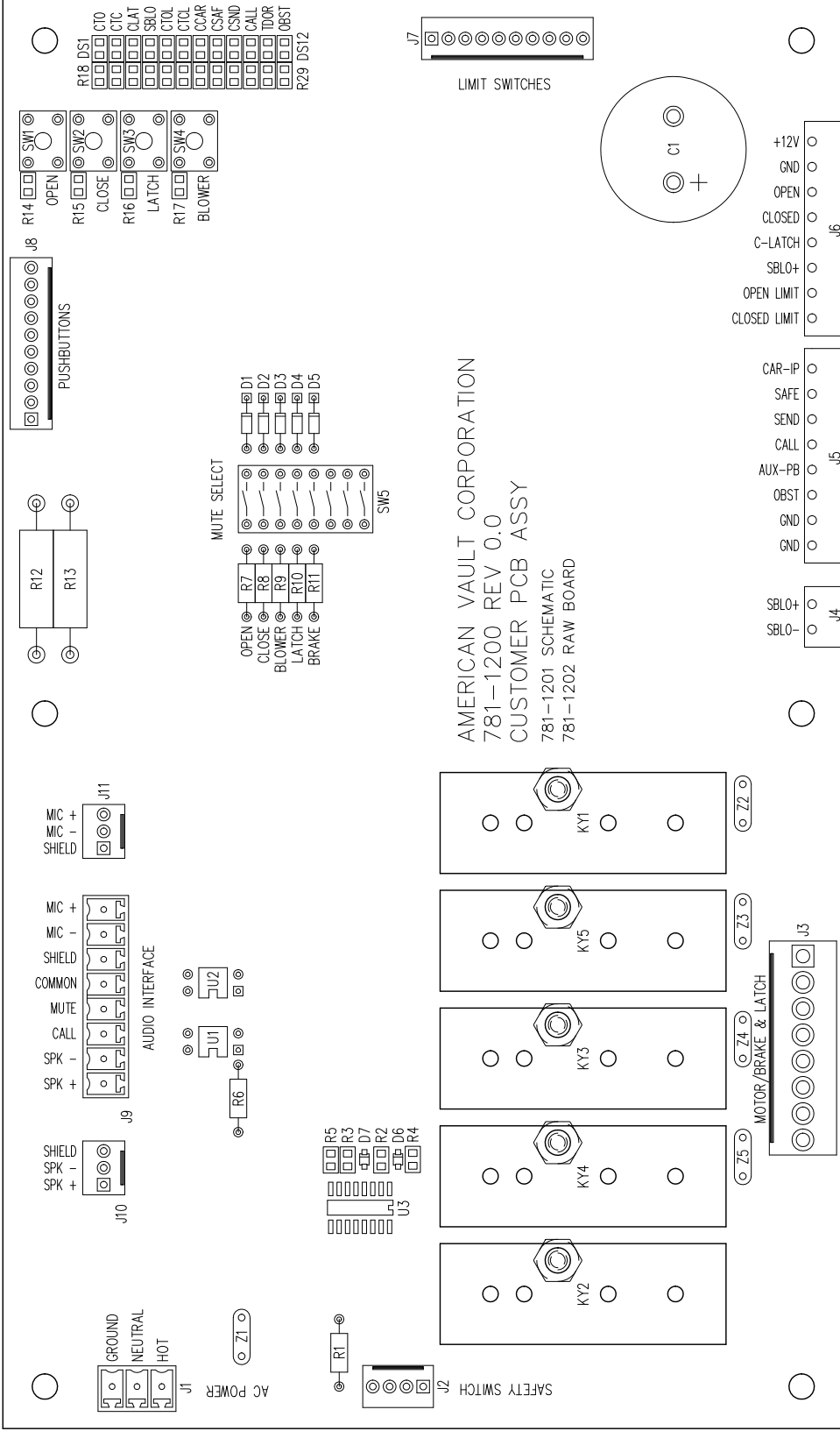

AMERICAN VAULT CORPORATION
 781-1200 REV 0.0
 CUSTOMER PCB ASSY
 781-1201 SCHEMATIC
 781-1202 RAW BOARD

DO NOT SCALE

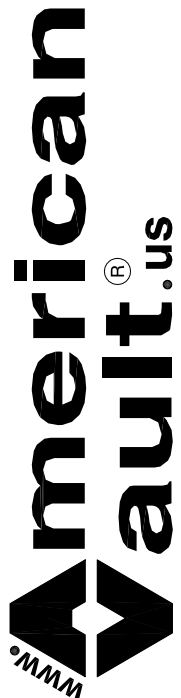

PRODUCT APPLICATION DRAWING
 PART NAMES
 781 CTS C/T PCB ASSY

SIZE	DWG NO	DATE	SHEET
A	FIGURE 5-4	01.20.2009	1 OF 1

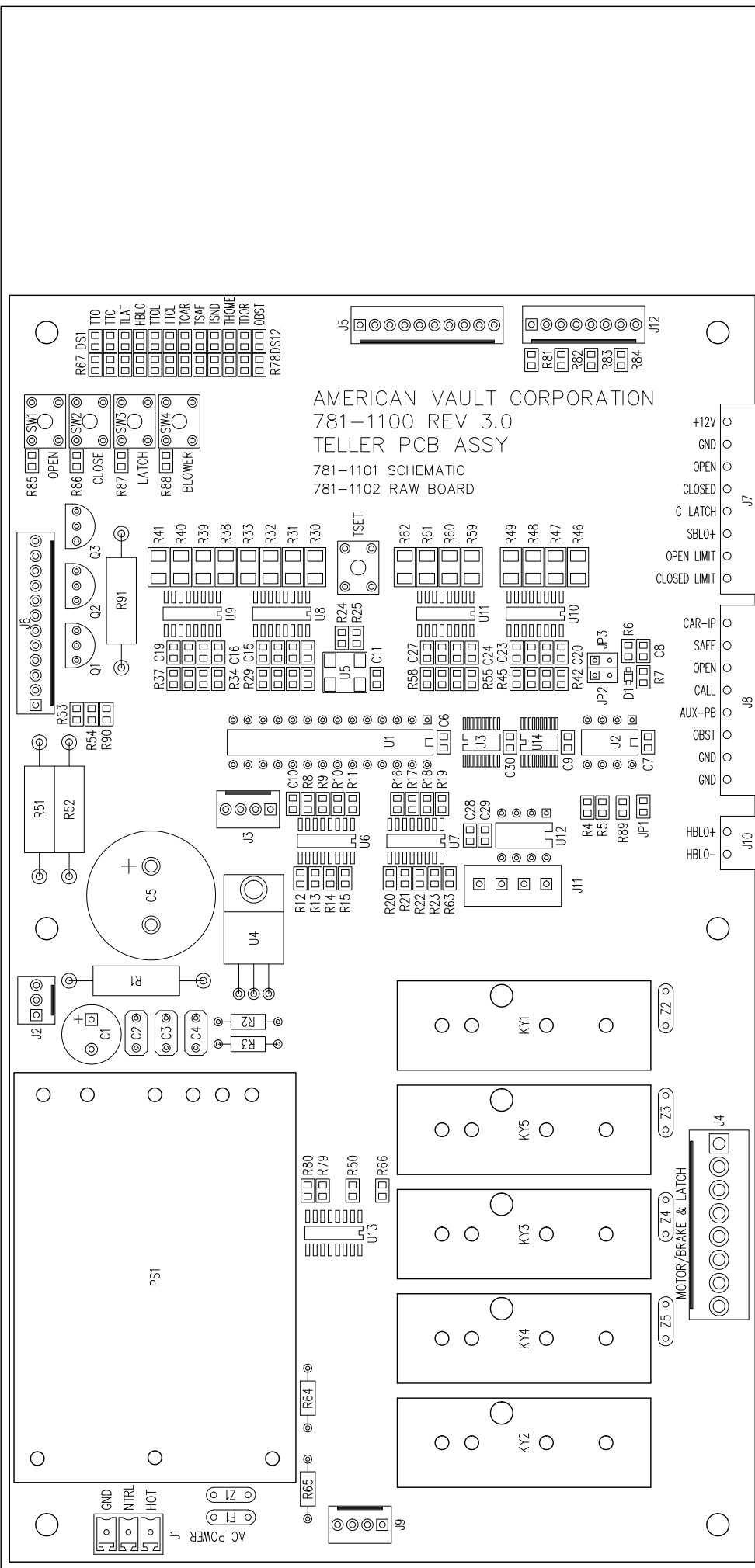

DO NOT SCALE

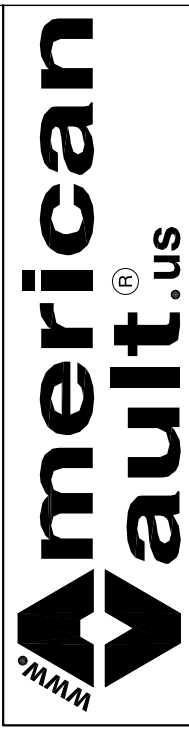

PRODUCT APPLICATION DRAWING
 PART NAMES
 781 CTS T/T PCB ASSY

SIZE	DWG NO	DATE	SHEET
A	FIGURE 5-5	01.20.09	1 OF 1